

Our Experience Is The Shaping Of The Uppers

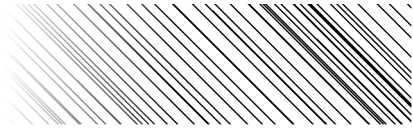

Multiform 4

Versatile Backpart Moulding Machine With Two Hot & Two Cold Stations

- Individual pincers
- Over-stretching system
- High heel uppers up to 14mm



Back-part moulding



Normal flanging



Mini - counter flanging



Stitch Down flanging
(On demand) **NEW**



Moccasin Flanging
(On demand)

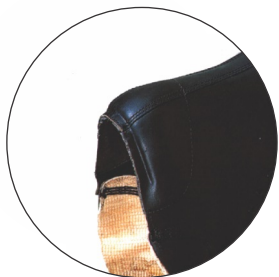

Goodyear flanging
(On demand)

5

Different shaping procedures in one machine

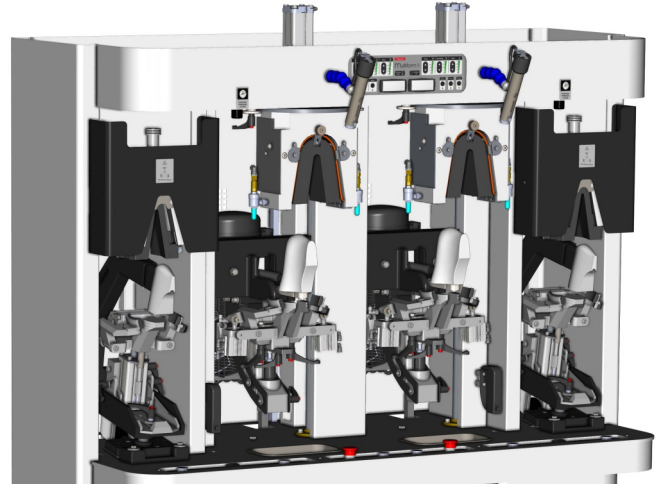

VERSATILE BACKPART MOULDING MACHINE WITH TWO HOT & TWO COLD STATIONS

3 revolutionary patented systems:

- Rotating cushion system with integrated wipers
- Divided Independent Pincers
- Inclined hot station pincers

Multiform4 is a backpart moulding machine dedicated to the production of high quality shoes. Designed and created to be the fundamental and most powerful tool for shoemakers aiming for perfection. Multiform4 shapes with equal ease high quality women's, men's and children's uppers, as well as boots, moccasins, and mini counters.

Thermoplastic or leatherboard counters

The standard version of this machine is equipped with two hot and two cold stations for thermoplastic counters, but it can be delivered on demand with four hot stations for maximum results on leatherboard counters too.

New Features:

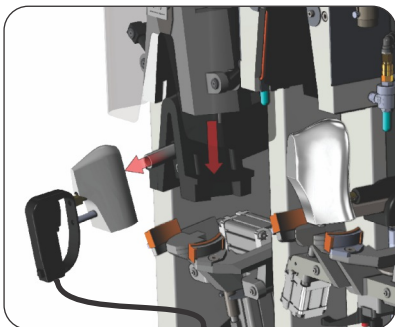

New quick release hot station mould system

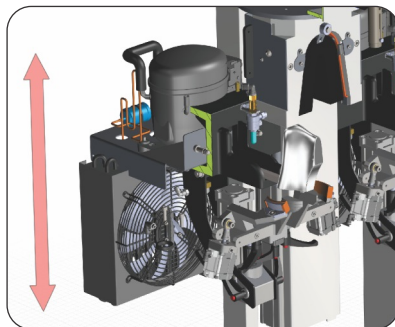

New redesigned moving cooling unit system with life time warranty



New redesigned led projector for accurate upper positioning

Back-part moulding

Divided Independent Pincers

The position of each Divided Pincer is adjusted independently according to the perimetrical shape of the aluminum last

- Adapted to last's shape
- Easy angle adjustment
- Quick adjustment

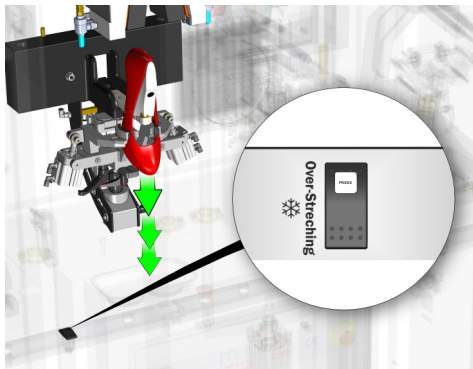
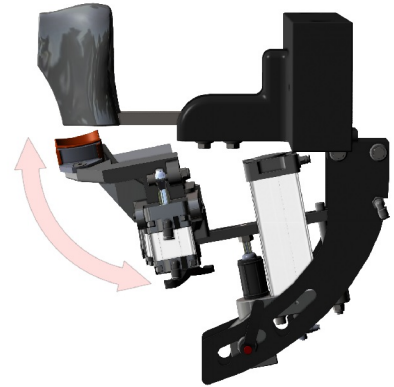
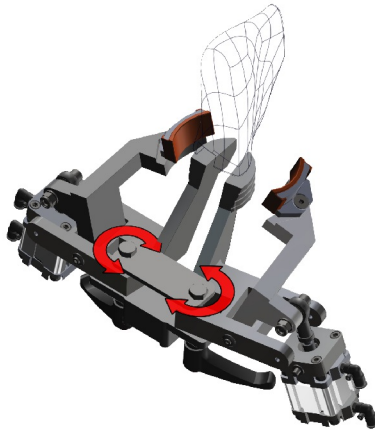

Over-stretching system

Same production uppers often are a little different and require different amount of pulling. Normally, the user pulls the uppers two or more times, and this leads to undesired extension.

Over-stretching system eliminates the above mentioned phenomenon and allows the user to add the minimum extra pulling that each upper requires.

Hot station pincers

New generation, hot station design, fully adjustable for flat and high level heel uppers

- Simple adjustments
- Universal lasts and moulds
- Inclination allows user to pull high-heeled shoes without harming the top line (up to 14cm)

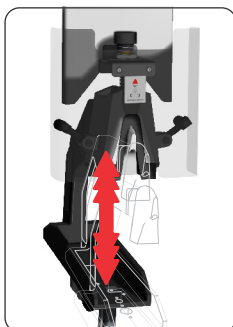
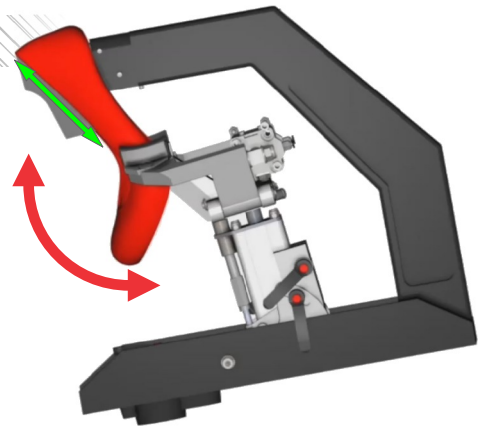

Brand New
stitch hammering function

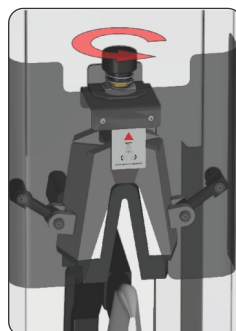

New designed lateral
pressure adjustment

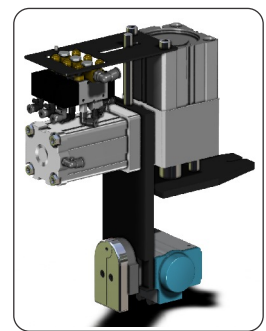

Brand New
stitch down device
(On demand)

Back-part moulding

ROTATING CUSHION SYSTEM WITH INTEGRATED WIPERS

The Multiform4 is equipped with the Olympic patented rotating cushion with integrated wipers which ensure a high perimetric pressure and shaping of the upper in combination with excellent upper flanging.

The patented cushion can be rotated in seconds allowing demanding procedures made simple and offers great versatility in production

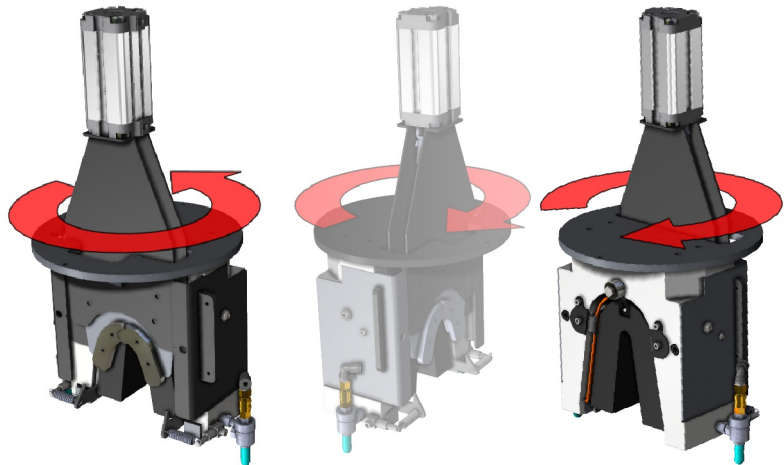

Mini counter moulding

Conversion time 2Min



Moccasin moulding

Conversion time 5Min

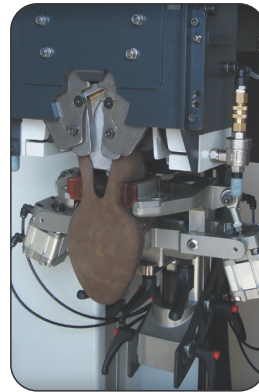

Multiform fits in any production

Conversion time 10Min



Cushion with integrated wipers & tubular
Male-female moulds
Thermoplastic counter
Flanging

Inflatable Cushion without wipers
Universal moulds
Excellent shaping
No flanging
Suitable for thermoplastic and leatherboard counters

TECHNICAL DATA

OPERATION	Electro - Pneumatic
PRESSURE	6 Bar
CAPACITY	1100 pairs per 8 hours max.
VOLTAGE	230V single phase 50Hz
POWER CONSUMPTION	2500 W
DIMENSIONS (mm)	1660 X 855 X 2030h
WEIGHT	560Kgs